

Article Info

Received: 22 Mar 2014 | Revised Submission: 10 Apr 2014 | Accepted: 20 May 2014 | Available Online: 15 Jun 2014

Harmonic Minimization in Grid-Tied Photovoltaic System

Shivam Sharma* and Durgesh Kumar**

ABSTRACT

With the increasing fears of the impacts of the high penetration rates of Photovoltaic (PV) systems, a technical study about their effects on the power quality of the utility grid is required. Since such study requires a complete modeling of the PV system in an electromagnetic transient software environment, for that MATLAB was chosen. This paper investigates a grid-tied PV system that is prepared in MATLAB. The model consists of PV array, DC link capacitor, DC-DC boost converter, single phase hysteresis current control inverter, AC inductive filter and a utility grid equivalent model. The paper starts with choosing MATLAB as the simulation environment and then by investigating the tasks of the different blocks of the grid-tied PV system model. It has also undertaken the various effects of variable atmospheric conditions (irradiation and temperature) on the performance of the different components in the model. DC-DC converter and inverter in this model use PWM and SPWM switching techniques, respectively. Finally, total harmonic distortion analysis on the inverter output current at PCC was applied and the values obtained were compared with the limits specified by the regulating standards such as IEEE Std 519-1992. This paper presents an overview of the matrix converter and its modulation techniques with application. Matrix converter is one of the most interesting members of power converter family; provide direct AC-AC conversion.

Keywords MATLAB/SIMULINK; Photovoltaic Systems; Total Harmonics Distortion (THD); Power System Simulation; Grid-Tied System; Hysteresis Current Control; Irradiation; Current Controller; Grid-Connected Photovoltaic System; Maximum Power Point Tracking.

1.0 Introduction

Due to the global concern about climate change and sustainable electrical power supply, renewable energy is increasingly becoming popular all over the world. Among different sources of renewable energy, the photovoltaic (PV) system is a promising energy source and the PV installations are increasing due to their environment-friendly operation [1]. The grid-connected PV system has gained popularity due to the feed-in-tariff and the reduction of battery cost. However, the intermittent PV generation varies with changes in atmospheric conditions.

Efficient control schemes are essential to deliver this maximum power with changes in atmospheric conditions.

The inclusion of proper controllers with a grid-connected PV system maintains the stable

operation under disturbances such as changes in atmospheric conditions, changes in load demands, or an external fault within the system. This can be performed by regulating the switching signal of the inverter, i.e., if a proper controller is applied through the inverter switches, the desired performance can be achieved. Normally, maximum power point tracking (MPPT) techniques [2], [3] are employed to perform this task and there is extensive literature on MPPT techniques in [4]–[6]. The perturb and observe (PO) [7] and incremental conductance methods are commonly used techniques in the area of PV systems. In the PO method, the derivative of power ($\frac{dp}{dt}$) and the derivative of voltage ($\frac{dv}{dt}$) need to be measured to determine the movement of the operating point.

If the ratio of ($\frac{dp}{dt}$) and ($\frac{dv}{dt}$) is positive, then the reference voltage is increased by a certain amount and vice versa [8]. In the incremental conductance

*Corresponding Author: Department of Electrical Engineering, Subharti University Meerut, Uttar Pradesh, India (E-mail: er.shivamsharma14@gmail.com)

**Department of Electrical Engineering, Subharti University Meerut, Uttar Pradesh, India

method, an MPPT is achieved by comparing the incremental conductance and instantaneous conductance of the PV arrays [9].

Current controllers are used to maintain the stable operation of a grid-connected PV system as they can regulate the current to follow the reference current. There are several techniques to control the current such as proportional integral (PI) controllers, hysteresis controllers, predictive controllers, sliding-mode controllers, and so on. In [10], a PI current control scheme is proposed to keep the output current sinusoidal and to have fast dynamic responses under rapidly changing atmospheric conditions. The difficulty of using a PI controller is the necessity of tuning the gain with changes in atmospheric conditions [11]. The hysteresis controller as proposed in [12] has fast response but a varying switching frequency. The predictive controller [13] overcomes the limitation of hysteresis controllers as it has constant switching frequency but it cannot properly match with changes in atmospheric conditions. An analytical method is proposed in [14] to determine the control parameters in steady state, but this method cannot be easily implemented during the fast transients which are natural in PV systems.

A sliding-mode current controller for a grid-connected PV system is proposed in [15]–[17] along with a new MPPT technique to provide a robust tracking against the uncertainties within the system. In [15]–[17], the controller is designed based on a time-varying sliding surface. However, the selection of a time-varying surface is a difficult task and the system stays confined to the sliding surface. Moreover, some intelligent control techniques such as neural network, genetic algorithm, fuzzy logic, etc. are used for the extraction of maximum power [18]–[20], and these methods extend the search space significantly. Recently, a dual carrier chaotic search algorithm was proposed in [21] to improve the search efficiency. However, the intelligent control techniques cannot capture the dynamics of the system accurately and the model-based controllers are more useful to perform this task efficiently. The grid-connected PV systems are nonlinear systems in which most of the nonlinearities occur due to the intermittency. The aim of this paper is to design a new current controller through partial feedback linearization to control the current injected into the grid. The performance of the proposed current control

scheme is also investigated in this paper under changes in atmospheric conditions.

The rest of the paper is organized as follows. The selection of Simulation package for the desired system is considered in section II. The SIMULINK/MATLAB model of a single-phase grid-connected PV system is shown in Section III. Section IV presents the brief overview of the PV system to prove the suitability of the proposed model. The design of a partial feedback linearizing controller for a single-phase grid-connected PV system is shown in Section V and the relationship between the MPPT and the proposed control scheme is shown in Section VI. Section VII shows the performance evaluation of the proposed controller under different atmospheric conditions. Finally, the paper concludes with a comment on future trends and further recommendations in Section VII.

2.0 Selection of Simulation Environment

Several simulation packages are available in the market which vary in their capabilities, simulation speeds and prices and how rich their libraries are. Some examples of widely used simulation platforms are Simulink Sim-Power Systems, MATLAB and PSCAD. These packages were compared in [1] using a simple two area system which consists of four machines connected by a transmission line. Both Simulink Sim-Power Systems and PSCAD don't allow interface to hardware for closed loop studies. Thus MATLAB has been chosen for the simulink of the photovoltaic system which makes it possible to analyze the circuit without hardware interface which makes it cost effective and result oriented.

This paper presents a new nonlinear current control scheme for a single-phase grid-connected photovoltaic (PV) system. The controller is designed using partial feedback linearization which linearizes the system partially and enables the controller design scheme for reduced-order PV systems. The reference current is calculated from the maximum power point tracking system. The proposed current control approach introduces the internal dynamics and the stability of the internal dynamics is a key requirement for the implementation of the controller. The performance of the controller is evaluated based on the tracking of grid current to the reference current by considering the changes in atmospheric conditions.

To ensure the suitability of the proposed controller in a real system, a large system similar to a practical system is simulated under different operating conditions such as changes in atmospheric conditions and faults on various parts of the system and compared with conventional controllers. The experimental validation of the proposed control scheme is also presented in this paper. The system is simulated through MATLAB.

3.0 PV System Model

The schematic diagram of a single-phase grid-connected PV system, which is the main focus of this paper, is shown in Fig. 1. The PV system consists of a PV array, a dc-link capacitor C, a single-phase inverter, and a filter inductor connected to the grid with the voltage. In this paper, the main target is to control the current injected into the grid by means of appropriate control signals through the switches of the inverter. The mathematical model of the system is presented in the following sections.

The effect of varying the input irradiation and temperature on the short circuit current and open circuit voltage, respectively, is shown in Eqn.1 and Eqn. 2. Increasing the irradiation increased the short circuit current while increasing the temperature decreased the open circuit voltage. Please notice that some of the values in the table might be out of the expected range due to the fact that the default values were calculated for a single or group of PV modules combined together and then input in the model as the value for a single solar cell.

3.1 PV cell and array modeling

The short-circuit current (I_{sc}) from a cell is nearly proportional to the illumination, while the open-circuit voltage (V_{oc}) may drop only 10% with an 80% drop in illumination [1]. The important result of these two effects is that the power of a PV cell decreases when light intensity decreases and/or temperature increases. The amount of power generated by a PV cell depends on the operating voltage of the PV cell array. It's V-I and V-P characteristic curves specify a unique operating point at which maximum possible power is delivered. The point at which the PV operates at highest efficiency is called the maximum power point (MPP). The light generated current (I_{pv}) is the function of solar irradiance and environmental temperature. The little

impact has also been shown by the wind speed. Irradiance has direct relation while working temperature has inverse relation to the I_{pv} .

Fig 1: Single-Diode Model of the Theoretical PV Cell and Equivalent Circuit of a Practical PV Cell

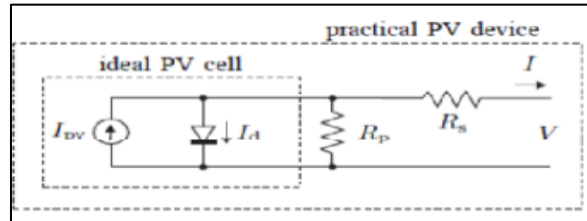

Practical PV device is composed of several connected PV cells and the observation of the characteristics at the terminals of the PV array requires the inclusion of additional parameters to the basic equations given by Eq.1 [2].

$$I = I_{pv} - I_0 \left[\exp\left(\frac{V + R_s I}{V_t * a}\right) - 1 \right] - \frac{V + R_s I}{R_p} \dots\dots\dots(1)$$

Where,
 I_{pv} and I_0 are the PV and saturation currents of module, $V_t = N_s k T / q$ is the thermal voltage of the array with N_s cells connected in series, R_s = equivalent series resistance and R_p = equivalent parallel resistance of the array of N_s cells in series.
 The value of the diode constant 'a' may be arbitrarily chosen usually $1 \leq a \leq 1.5$ [3]. If the array is composed of N_p parallel connections of cells then the saturation currents is given by $I_0 = I_0, cell * N_p$. and module current is modified to $I_{pv} = I_{pv}, cell * N_p$.

Fig 2: Simulink Model of PV Module

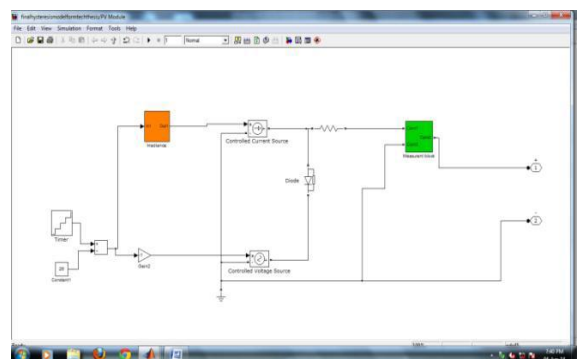

Fig. 2 shows the Simulink model of PV Module containing the constant Irradiance values with its respective temperature constants forming a complete PV circuit including controlled Voltage and Current Source respectively at desired DC values.

Also in context with that two subsystems in orange and green background are shown in the fig. 2 containing the irradiance unit and the measurement section of the PV module which are also shown below using MATLAB/SIMULINK models.

The effect of solar irradiance and cell temperature on light generated current of solar PV is given by the Eq. 2 as follows [4]

$$I_{pv} = (I_{pv,n} + K_i * \Delta T) \frac{G}{G_n} \dots\dots\dots(2)$$

Where,

I_{pv} , n[A] = Light-generated current at the nominal condition, Ampere

ΔT [K] = T-T_n (T and T_n the actual and nominal temperatures respectively), Kelvin

G [W/m²] = Irradiation on the device surface, and G_n [W/m²] = Nominal irradiation.

K_i = Temperature coefficient of cell for the short circuit current

And diode saturation current I₀ also depends on nominal open circuit voltage (V_{ocn}) and temperature coefficient of cell for the open circuit voltage (K_v) given by equation below [5]

$$I_0 = \frac{I_{sc,n} + K_i * \Delta T}{\exp\left(\frac{V_{ocn} + K_v \Delta T}{a * V_t}\right) - 1} \dots\dots\dots(3)$$

This modification aims to match the open-circuit voltages of the model with the experimental data for a very large range of temperatures. The ambient temperature sets the base temperature of the module and the irradiance predominantly sets the temperature raise of the module, which is about 0.028oC per W/m².

The research work reported in [6] says that wind speed and ambient humidity slightly influence the module temperature whereas the wind direction influence is negligibly small.

4.0 Single-Phase Grid-Connected Pv System Modeling

Fig 3: Equivalent Circuit Diagram of Single-Phase Grid-Connected PV System

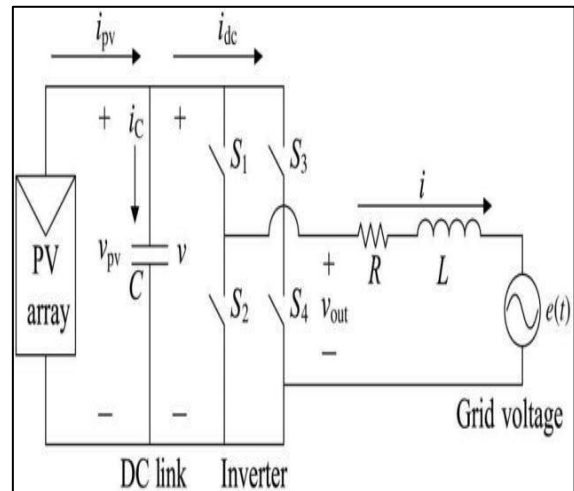
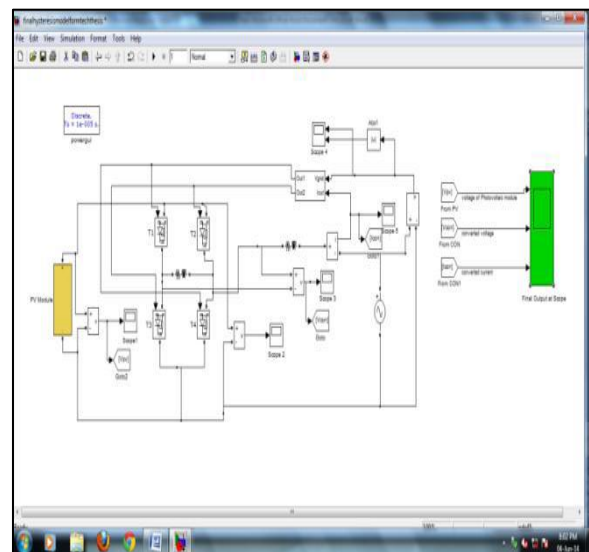

Fig 4: Simulink Model of PV Based Grid-Tied System



Above model in fig.8 is analyzed and designed through MATLAB, which forms a Grid-Tied Photovoltaic System in which PV output is given to the single phase inverter which is fed through the pulse provided by the conversion of the utility grid voltage. The respective output voltage and current for the PV based grid-tied system is analyzed

through the output responses obtained through the respective scopes.

Fig 5: Final Responses Obtained Through PV Based Grid-Tied System

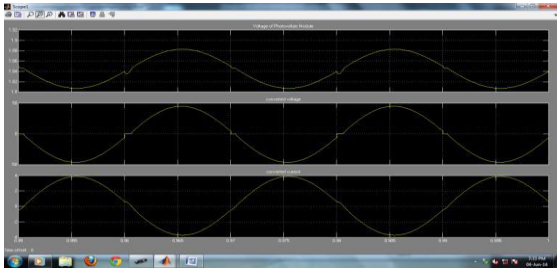

5.0 MPPT Algorithm and Calculation of Reference Value

Maximum Power Point Tracker (MPPT) is used to operate the module at the peak power point so that the maximum power can be delivered to the load under varying temperature and irradiance conditions. A DC to DC converter serves the purpose of transferring maximum power from the solar PV module to the load by changing the duty cycle of it and load impedance as seen by the source is varied and matched at the point of the peak power with the source so as to transfer the maximum power.

Among various algorithms, Perturb and Observe (P&O) algorithm is used in this work for the MPP tracking. A slight perturbation is introduced to the system, due to this perturbation, the power of the module changes.

If the power increases due to the perturbation then the perturbation is continued in that direction. After the peak power is reached the power at the next instant decreases and hence after that the perturbation reverses [7][8]. The Matlab/Simulink model has shown in Fig. 4.

The filtered current and voltage signals (I_{pv_F} and V_{pv_F}) are then fed into the MPPT control block that uses the Incremental Conductance Tracking Algorithm.

An algorithm that is based on the fact the slope of the PV array power curve shown in Fig. 7 is zero at the Maximum Power Point (MPP), positive on the left of the MPP, and negative on the right. The MPP can thus be tracked by comparing the instantaneous conductance (I/V) to the incremental conductance (ΔI/ΔV) [11].

$$\frac{\Delta i_{pv}}{\Delta v_{pv}} = -\frac{i_{pv}}{v_{pv}}$$

Here, $\Delta i / \Delta v$ is the incremental conductance. The MPP can be obtained by considering the following conditions:

- 1) At the MPP, $\frac{\Delta i_{pv}}{\Delta v_{pv}} = -\frac{i_{pv}}{v_{pv}}$
- 2) At the left of MPP, $\frac{\Delta i_{pv}}{\Delta v_{pv}} > -\frac{i_{pv}}{v_{pv}}$
- 3) At the right of MPP, $\frac{\Delta i_{pv}}{\Delta v_{pv}} < -\frac{i_{pv}}{v_{pv}}$

If a PV system satisfies condition 1, the voltage is ascertained at the MPP voltage v^* and fixed at this voltage until the MPPT encounters a change due to the changes in atmospheric conditions. If the atmospheric conditions change in such a way that the PV system holds condition 2, then it is essential to increase the reference voltage to achieve the MPPT and the opposite is true for condition 3.

The MPPT technique adjusts the PV array voltage in order to extract the available maximum power under all atmospheric conditions. The MPPT

uses v^* and i^* to detect the slope and generates P_{ref} to track the maximum power [17]. In this paper, an incremental conductance method as presented is used to obtain the maximum power. At maximum power point (MPP).

Fig 6: Model for MPPT Simulink Model for P&O Algorithm

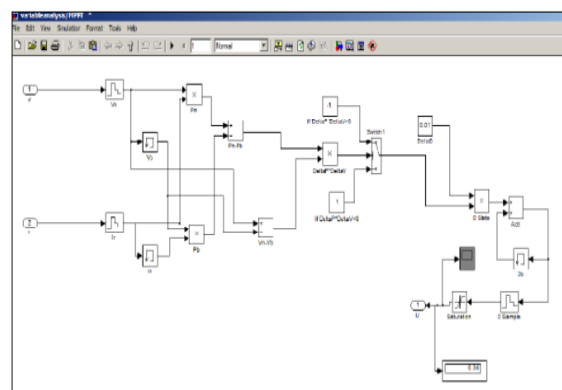
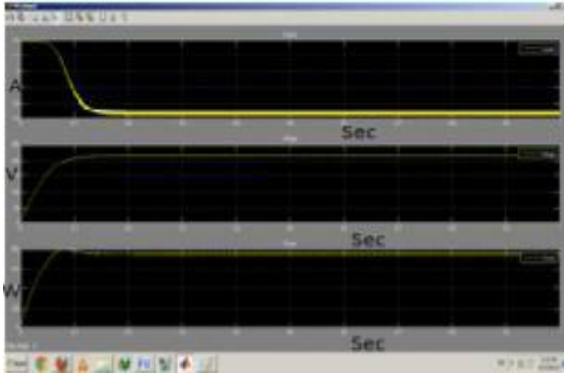

Fig 7: Output Current, Voltage and Power from PV Array Without MPPT



6.0 Conclusion

Grid tied inverters convert DC power to AC power with an efficiency of 90% or more most of the time. Inverters can even work to some extent when irradiance levels up to 200W/m², but performance starts to drop off dramatically when irradiance levels falls below it.

The use of MPPT system is of great value to the array output as it (P&O algorithm) optimizes the PV power output by 23% than without the use of MPPT system. The nonlinear devices used in the converter circuits are the great source of harmonics in the PV grid connected system. The harmonics generated in the PV power converting systems greatly vary with the solar irradiance. The odd harmonics have greater impacts on power quality than even harmonics as they have higher magnitude. The current THD is more sensitive on the fluctuation of solar irradiance than the respective voltage THD. Current THD greatly decreases with the increase in the solar irradiance while voltage THD slightly increases with increase in solar irradiance. Power factor varies linearly for values of solar irradiance lower than 200 W/m² and remains close to unity for higher solar irradiance values. In addition, reactive power injection increases at low irradiance.

It has found that current THD is 21.35% and fundamental or 1st harmonic component (50Hz) is 4.124A_{peak} (2.91Arms). The even harmonics are much less than the odd harmonics and they have severe impacts on power quality. Similarly, voltage signal contained 5.01% of THD with fundamental components of 312.8 V_{peak} (221.18Vrms). The details of even and odd harmonics are shown in Table

I. Since the harmonics present in the inverter output are higher than the IEEE 159 standard (below 5%), harmonic filter is used for suppression of harmonics.

Fig 8: Active and Reactive Power Variation at Inverter Output

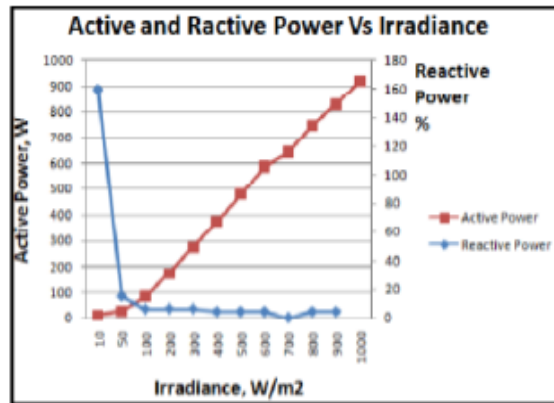

References

- [1] Y. T. Tan, D. S. Kirschen, N. Jenkins, Impact of a large penetration of photovoltaics on the power system,” in Proc. CIRED 17th Int. Conf. Electricity Distribution, Barcelona, Spain, 2003
- [2] D. Casadei, G. Grandi, C. Rossi, Single-phase single-stage photovol-taic generation system based on a ripple correlation control maximum power point tracking, IEEE Trans. Energy Convers., 21(2), 562–568, 2006
- [3] I. Houssamo, F. Locment, M. Sechilariu, Maximum power point tracking for photovoltaic power system Development and experimental comparison of two algorithms, Renew. Energy, 35(10), 2381–2387, 2010
- [4] T. Eram, P. L. Chapman, Comparison of photovoltaic array maximum power point tracking techniques,” IEEE Trans. Energy Convers., 22(2), 439–449, 2007
- [5] M. E. Ropp, S. Gonzalez, Development of a MATLAB/Simulink model of a single-phase grid-connected photovoltaic system, IEEE

- Trans. Energy Convers., 24(1), 195–202, 2009
- [6] B. D. Subudhi, R. Pradhan, A comparative study on maximum power point tracking techniques for photovoltaic power systems, *IEEE Trans. Sustain. Energy*, 4(1), 89–98, 2013
- [7] A. Mellit, H. Rezzouk, A. Messai, B. Medjahed, FPGA-based real time implementation of MPPT controller for photovoltaic systems, *Renew. Energy*, 36(5), 1652–1661, 2011
- [8] L. Chun-xia, L. Li-qun, An improved perturbation and observation MPPT method of photovoltaic generate system, in *Proc. 4th IEEE Conf. Industrial Electronics and Applications*, Xi'an, China, 2009
- [9] B. Liu, S. Duan, F. Liu, P. Xu, Analysis and improvement of maximum power point tracking algorithm based on incremental conductance method for photovoltaic array,” in *Proc. IEEE PEDS*, Bangkok, Thailand, 2007
- [10] J. Selvaraj, N. A. Rahim, Multilevel inverter for grid-connected PV system employing digital PI controller, *IEEE Trans. Ind. Electron.*, 56(1), 149–158, 2009
- [11] P. P. Dash, M. Kazerani, Dynamic modeling and performance analysis of a grid-connected current-source inverter-based photovoltaic system, *IEEE Trans. Sustain. Energy*, 2(4), 443–450, 2011
- [12] N. A. Rahim, J. Selvaraj, C. C. Krismadinata, Hysteresis current control and sensorless MPPT for grid-connected photovoltaic systems, in *Proc. IEEE Int. Symp. Industrial Electronics*, Vigo, Spain, 2007, 572–577
- [13] A. Kotsopoulos, J. L. Duarte, M. A. M. Hendrix, A predictive control scheme for DC voltage and AC current in grid-connected photovoltaic inverters with minimum DC link capacitance, in *Proc. 27th Annu. Conf. IEEE Industrial Electronics Society*, Colorado, USA, 2001, 1994–1999
- [14] S. S. Ahmed, M. Mohsin, Analytical determination of the control parameters for a large photovoltaic generator embedded in a grid system,” *IEEE Trans. Sustain. Energy*, 2(2), 122–130, 2011
- [15] I. Kim, Sliding mode controller for the single-phase grid-connected photovoltaicsystem, *Appl. Energy*, 83(10), 1101–1115, 2006
- [16] E. Bianconi, J. Calvente, R. Giral, E. Mamarelis, G. Petrone, A. Ramos-Paja, G. Spagnuolo, M. Vitelli, A fast current-based MPPT technique employing sliding mode control, *IEEE Trans. Ind. Electron.*, 60(3), 1168–1178, 2013
- [17] I. Kim, Robust maximum power point tracker using sliding mode control-ler for the three-phase grid-connected photovoltaic system, *Solar Energy*, 81(3), 405–414, 2007.
- [18] G. E. Ahmad, H. M. S. Hussein, H. H. El-Ghetany, Theoretical analysis and experimental verification of PV modules, *Renewable Energy*, 28(8) 1159–1168, 2003
- [19] H. S. Rauschenbach, *Solar cell array design handbook*, Van Nostrand Reinhold, 1980.
- [20] C. Carrero, J. Amador, S. Arnaltes, A single procedure for helping PV designers to select silicon PV module and evaluate the loss resistances, *Renewable Energy*, 2007
- [21] Xuejun Liu, A. C.Lopes, An Improved Perturbation and Observe Maximum Power Point Tracking Algorithm for PV Arrays, *IEEE PESC*, 2005–2010, 2004
- [22] D. Sera, R. Teodorescu, P. Rodriguez, PV panel model based on datasheet values, In *Proc. IEEE International Symposium on Industrial Electronics*, ISIE, 2392–2396, 2007.